

Document Version Control		
Document Number	Version Number	Release Date
<b>WP0019</b>	<b>0</b>	<b>20/05/2022</b>

# ADAPTOR LEG COVER WELDING PROCEDURE

---

## OUTLINE

This procedure provides an outline of how to attach the Talon Adaptor Leg Cover (ALC) onto Adaptor leg. Please ensure a copy of this procedure is available for personnel who are tasked with welding Talon products.

## WELDING SAFETY

Welding, cutting and any allied process are a significant safety risk. Before undertaking any of these processes ensure that all precautions have been considered or implemented as per welding safety standards AS1674: 2007 or ANSI Z49.1: 2005 or equivalent globally recognized standard.

Of particular note please ensure the following is adhered to:

- Wear correct PPE including
  - Full sleeve non-flammable work wear. (No gaps)
  - Non-flammable welding gloves
  - Steel capped work boots
  - Safety glasses
  - Hearing protection
  - Full face welding shield
- Suitable ventilation is available for the person completing the operation.
- Welding is an electrical risk ensure the area where welding is to be conducted is not damp or wet.
- Welding is a fire risk ensure the area where welding is to be conducted is free of any thing flammable and that suitable fire extinguishers are easily available.
- If welding is to be conducted in an area where other people are working, ensure welding flash shields are utilized.
- Good general housekeeping to ensure the work area is safe and free of clutter.
- Ensure appropriate tags for your workplace and work environment are used.

Document Version Control		
Document Number	Version Number	Release Date
<b>WP0019</b>	<b>0</b>	<b>20/05/2022</b>

## WELDING PROCESS AND PREHEAT NOTICE



Please ensure that you follow the Thermal Treatment (Preheat) procedure stated in this welding procedure. Preheat of the weld area prior to commencing welding will help ensure weld quality, reduce the occurrence of cracking and other problems that can result in costly rework. The weld area must be heated to 150°C, measured at least 100mm / 4" away from and either side of the weld joint and maintained between 150°C and 250°C throughout the welding process.

The warranty may be void on Talon Weld-On components if the specified process is not followed correctly.

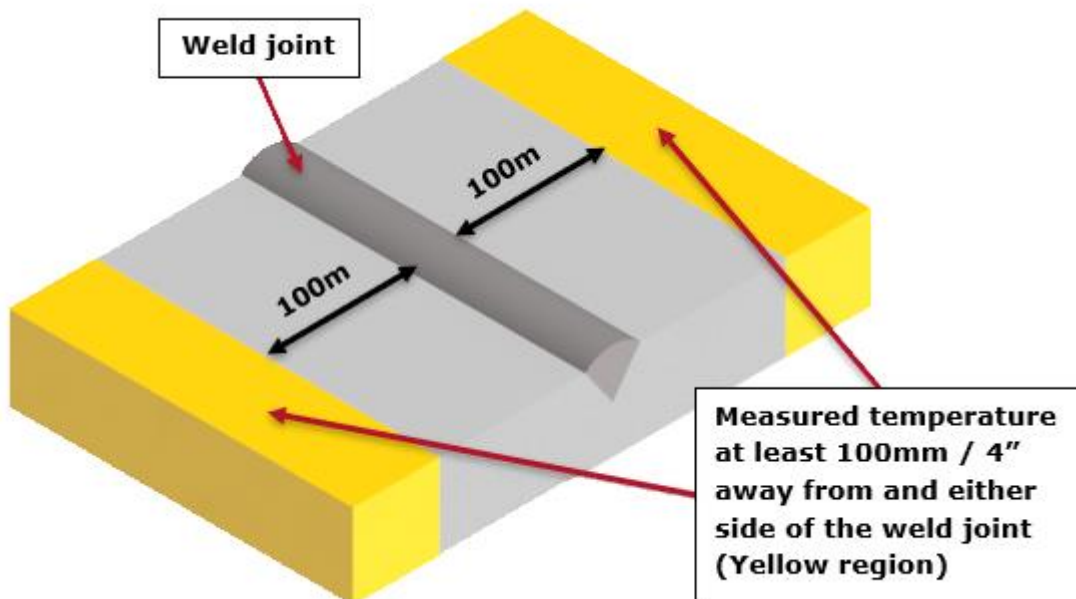

Document Version Control		
Document Number	Version Number	Release Date
<b>WP0019</b>	<b>0</b>	<b>20/05/2022</b>

## TALON WELDING SETUP

### WELD PREPARATION

The surfaces to be welded must be good and free from scale, grease, paint, water, or any other contaminants. The heat from welding breaks down any hydrocarbons and moisture in the area and releases hydrogen. The hydrogen along with any remaining particulate matter can be absorbed in the weld and result in cracking, porosity, and inclusions.

Preparation of the weld surfaces may be achieved by sand blasting, shot blasting, grinding, sanding, air carbon arc gouging, or a combination of any these processes. Should the air carbon arc gouging process be used, finish the surface by grinding to remove all carbon slag. Following any of these preparation processes ensure any dust or particulate matter is removed from the weld area to prevent porosity and inclusions.

### WELDING PROCESS

Welding may be completed by any of the following processes:

- Gas Metal Arc Welding (GMAW)
- Flux-cored Arc Welding (FCAW)

A combination of GMAW or FCAW can be utilised.

The following table details **recommended** reference consumables:

Process	AWS	AS/NZS	ISO	Shielding Gas	Polarity
GMAW	AWS A5.18 ER70S-4	2717.1: ES4-GC/M-W503AH		100% CO2 Ar + 10-15%CO2 Ar + 15-25%CO2	DC+
GMAW	AWS A5.18 ER70S-6	2717.1: ES6-GC/M-W503AH		100% CO2 Ar + 10-15%CO2 Ar + 15-25%CO2	DC+
FCAW-G	AWS A5.20 E71T-1 H8	17632-B: T49 2 T1 1 CAU H10		100% CO2 Ar + 20-25%CO2	DC+
FCAW-G	AWS A5.18 E70C-6M H4	17632-B: T49 4 T15 0 MAU H5		Ar + 20-25%CO2	DC+/-
FCAW-S	AWS A5.20 E70T-7	17632-B: T49 Z T7 0 NA		NR	DC-
FCAW-S	AWS A5.20 E71T-8	17632-B: T49 3 T8-1NA-H15		NR	DC-

### ELECTRICAL PARAMETERS

The person completing the weld should refer to the manufacturer's specifications to determine the optimal settings to complete the weld. Actual voltage, welding current and Electrode Stick Out (E.S.O.) used will depend on machine characteristics, plate thickness, run size, shielding gas and operator technique etc.

Document Version Control		
Document Number	Version Number	Release Date
<b>WP0019</b>	<b>0</b>	<b>20/05/2022</b>

### WELDING POSITION

Welding of Talon Adaptor Leg Cover is recommended and shall be completed in the Flat 1F and Horizontal 2F position. The other positions can be welded but the process should be adjusted to suit the applicable weld wire and equipment to ensure good weld strength and integrity.

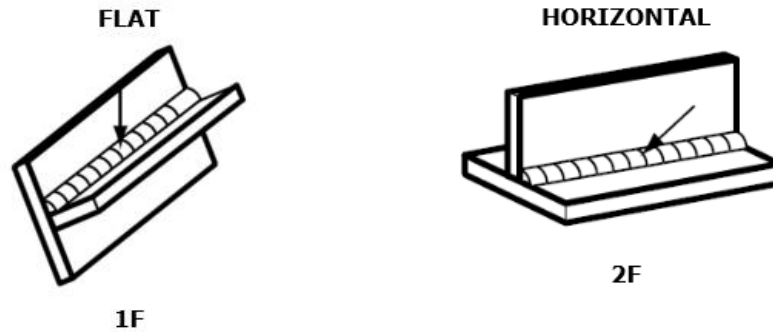

Deviation from the Flat or Horizontal position is permissible as shown in figure below as typically described in welding standard AWS D1.1, Structural Welding--Steel, Figure 4.2 "Positions of Fillet Welds".

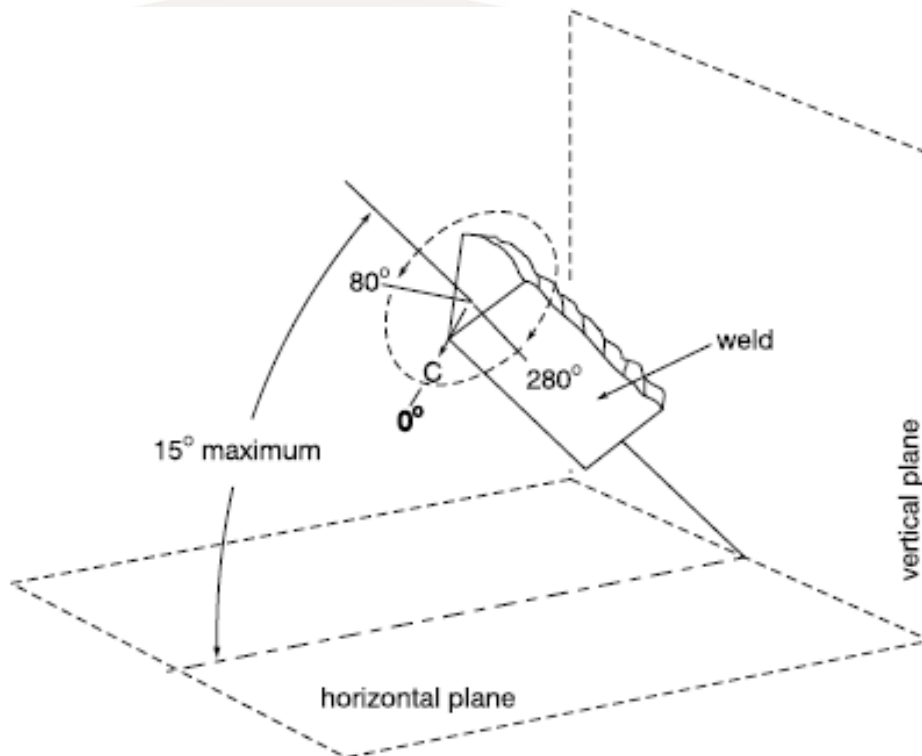

The longitudinal axis of the weld may be inclined no more than 15° with respect to the horizontal plan. The centre of the weld face "C" must lie within the rotational limits of 80° to 280° as shown.

Document Version Control		
Document Number	Version Number	Release Date
<b>WP0019</b>	<b>0</b>	<b>20/05/2022</b>

## THERMAL TREATMENT

It is important to preheat the work piece prior to commencing welding and ensure the components are maintained within the acceptable interpass temperature range during welding. Preheat is the heating of a work piece prior to being welded, flame cut, or air carbon arc gouged. Heat can be applied through several methods such as propane or butane gas flame burners or torches and magnetic induction.

As welding, flame cutting and air carbon arc gouging use a high temperature heat source to melt the base metal, a high temperature in a small localized area is created along with a large temperature differential to the rest of the work piece. This causes high stresses, hardened areas, deformation, and a very small area for hydrogen gases to be released from the steel. Preheat reduces the temperature differential and so lowers the risk of weld cracking, maximum hardness of the heat affected zone, lessens distortion, and releases hydrogen from the steel prior to welding.

Maintaining the correct interpass temperature is important to hold the reduced temperature differential gained from preheating and to ensure the work piece does not get too hot. Allowing the steel to become too hot will temper the steel and soften it, reducing its hard-wearing properties.

When preheating with burners and torches it is most effective to heat the work piece from below. This allows the heat to soak up through the body of the work piece. Using insulating heat blankets on the topside of the work piece will improve and speed up the process, allowing the dispersion and retention of the heat that has been input.

Temperature should be measured using an infrared thermometer or temperature indicating crayon at least 100mm / 4" away from and either side of the weld joint. Best practice is to measure the temperature on the top side as heat is applied to the bottom side, this will ensure a complete preheat through the thickness of the work piece. Prior to any welding, flame cutting and air carbon arc gouging on Talon components and steel bodies the following preheat and interpass temperatures must be reached and maintained.

Material	Thickness	Min Preheat Temp	Max Interpass Temp
Talon GET Castings	All Weld-on Castings	150°C / 300°F	260°C / 500°F
ASTM A514 Steels	Greater than 63mm / 2-1/2"	120°C / 250°F	260°C / 500°F
400-450 BHN Abrasion Resistant Steel	Greater than 63mm / 2-1/2"	150°C / 300°F	260°C / 500°F

### Notes:

- If the ambient humidity is high and or the temperature is below 4°C / 40°F, the tabulated thermal treatment temperature should be increased by 27°C / 80°F. At no time should any material type or thickness be welded when the temperature of the steel is at or below 4°C / 40°F. This includes tack or spot welds or any allied process. Preheat must be applied as specified.
- All material within 100mm / 4" of the weld zone must be within the specified temperature.
- Cool weld slowly, for a minimum of 8 hours, utilising thermal blankets. Do not allow drafts or cool ambient temperatures to cool the parts or assembly. Cool down rate should not exceed 55°C / 130°F, per hour.
- If the ambient temperature is at or below 4°C / 40°F the part must be covered with a thermal blanket to insure the cool down rate above. Alternatively, the entire part maybe post-heated to 150 - 200°C / 300 - 400°F for four hours and then maybe air cooled.

Document Version Control		
Document Number	Version Number	Release Date
<b>WP0019</b>	<b>0</b>	<b>20/05/2022</b>

## WELDING PROCEDURE

Ensure the surface of the top and bottom Adaptor leg is clean. Remove any lifting lug to avoid interference with Adaptor Leg Cover (ALC).

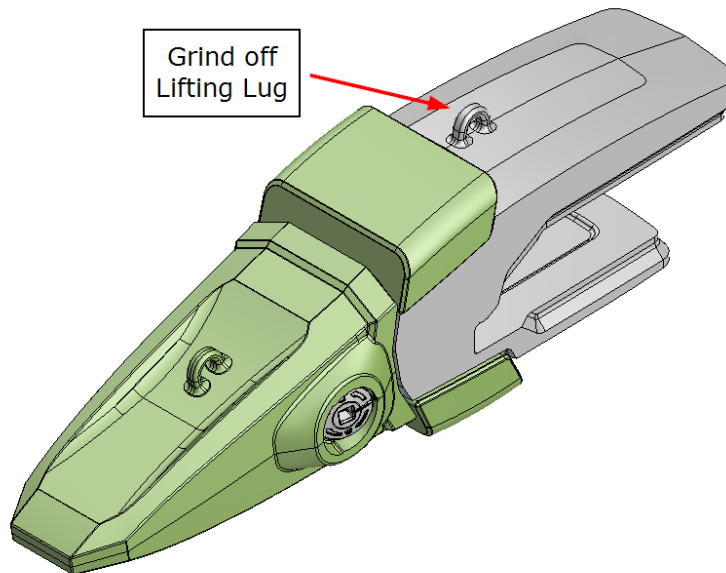

Two ALC can be used to fit over the top leg of the Adaptors by fully utilizing one uncut and the other partially cut to fill up the remaining leg length. Position the ALC on the top leg of Adaptor. Ensure the gap between HD Wear Cap and ALC is not more than 10mm.

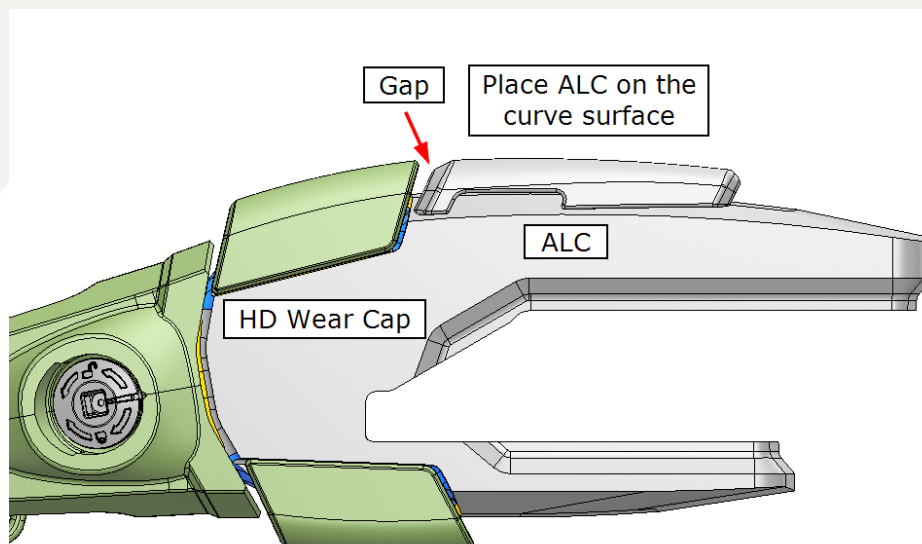

Document Version Control		
Document Number	Version Number	Release Date
<b>WP0019</b>	<b>0</b>	<b>20/05/2022</b>

Fix the ALC at the front position in place with one 12mm / 1/2" long tack weld at the root of the weld prep.

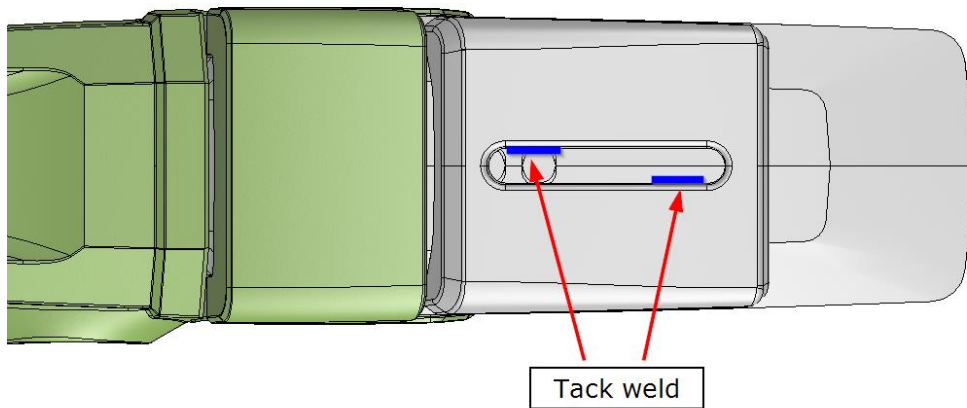

Then, position another ALC at the rear of the Adaptor so that the ALC can fully cover the rear leg of adaptor.

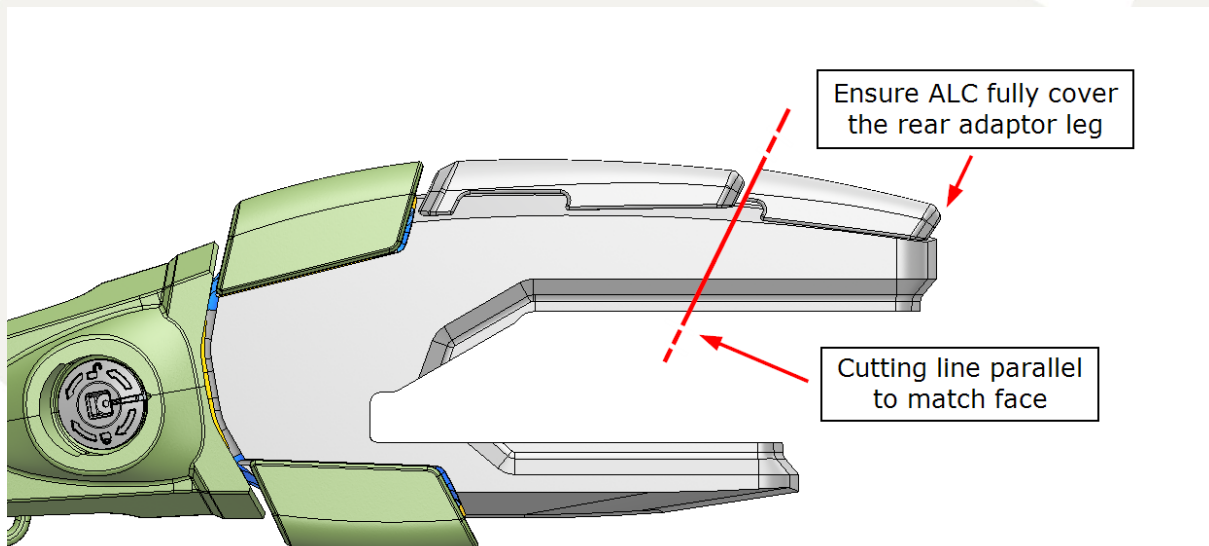

Document Version Control		
Document Number	Version Number	Release Date
<b>WP0019</b>	<b>0</b>	<b>20/05/2022</b>

Make a 12mm / 1/2" long tack weld at the root of the weld prep to secure the back ALC position in place.

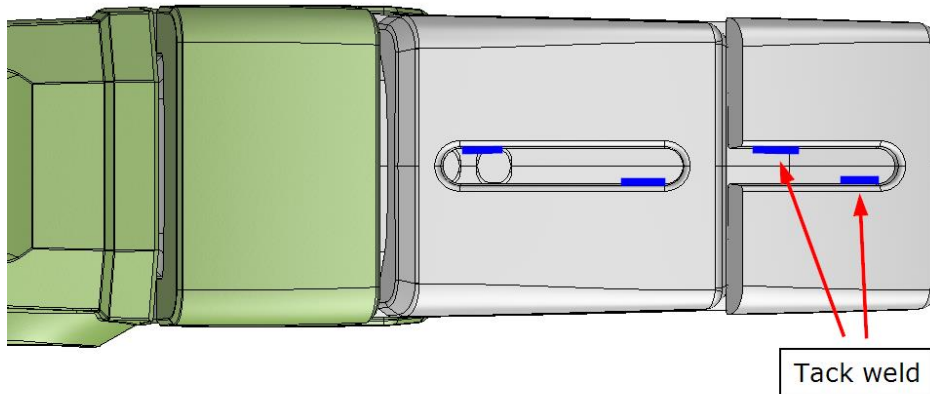

Preheat the Adaptor and ALC area to be welded to 150°C before proceeding with complete weld. Start welding on the area around the wear cap as specified in the figure below with a weld size of 20mm to 25mm fillet as shown. Mechanical attached GET should be removed prior the preheat and welding of the ALC.

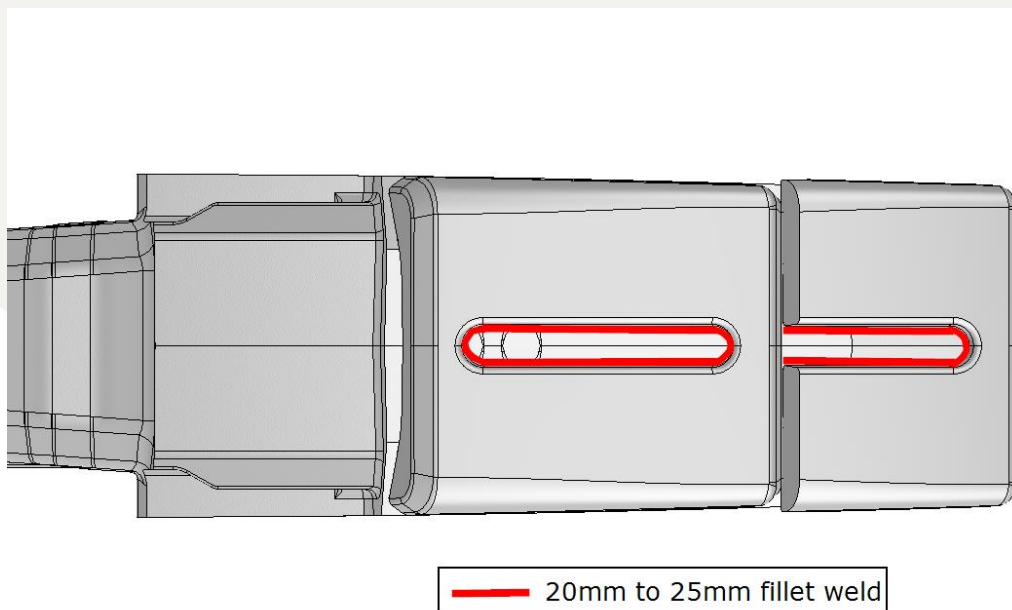



Document Version Control		
Document Number	Version Number	Release Date
<b>WP0019</b>	<b>0</b>	<b>20/05/2022</b>

Repeat the same steps as above for the Adaptor bottom leg. One piece of ALC will be used for the bottom leg of adaptor. Ensure gap and wear cap coverage area.

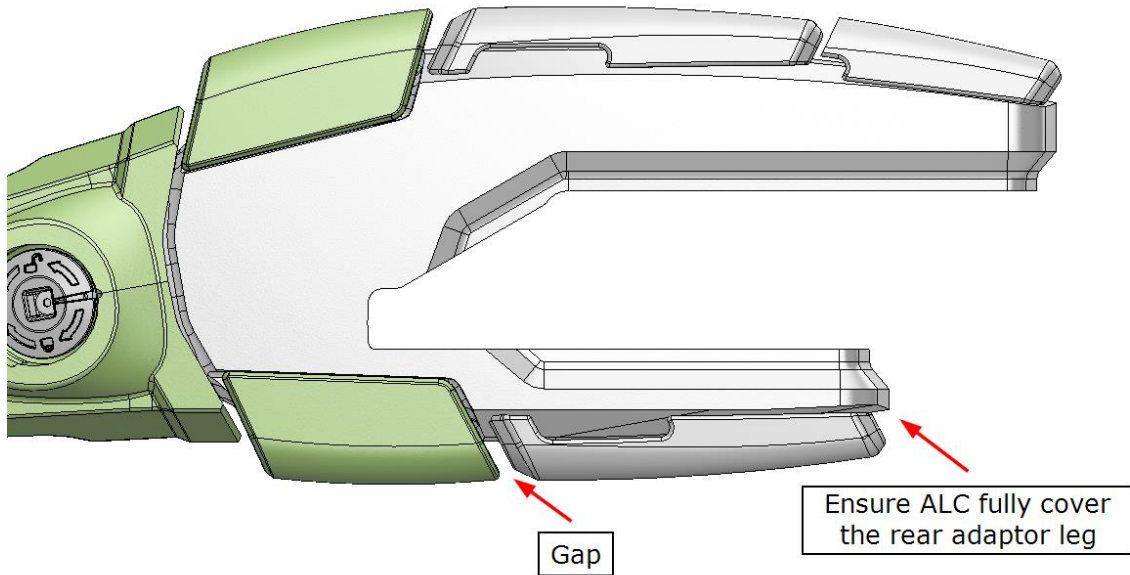

Final position how ALC are placed over the Adaptor is as below.

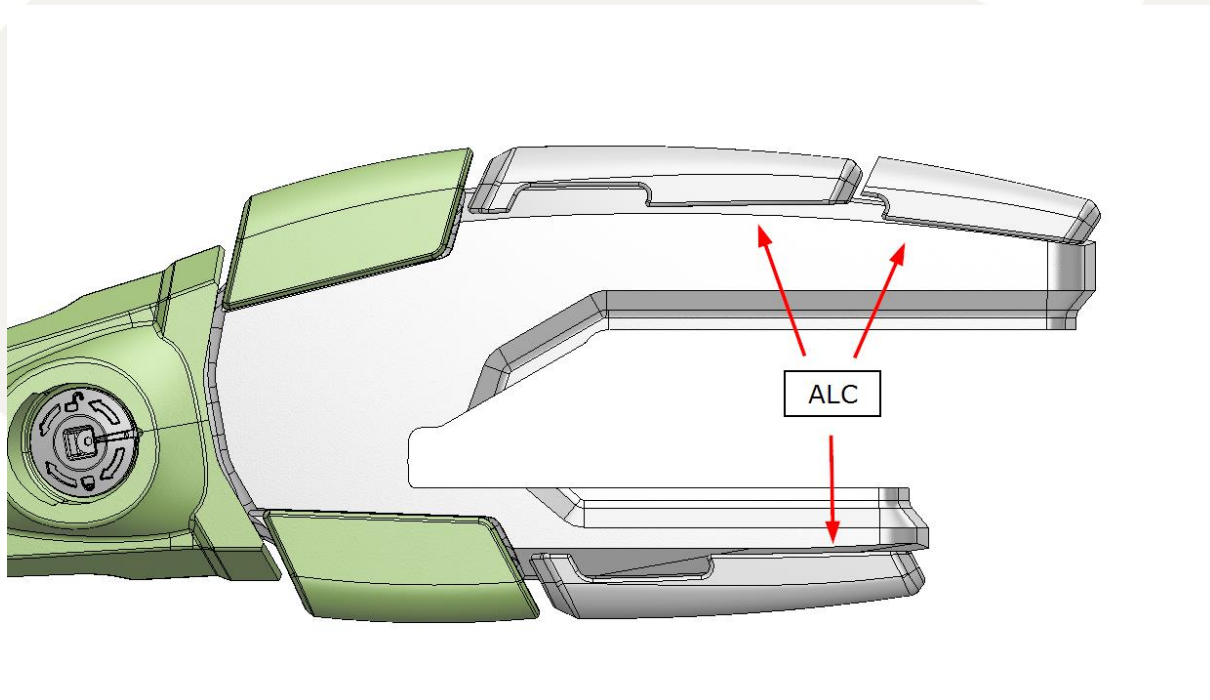

Document Version Control		
Document Number	Version Number	Release Date
<b>WP0019</b>	<b>0</b>	<b>20/05/2022</b>

### **WELDING SEQUENCE**

Maintaining the correct preheat and inter-pass heat. Build up the weld alternating between ALC and the adaptor surface. This is to allow for the distribution of heat into the parent metal and minimize risk of distortion.

Depending on your electrode size and weld metal deposition rate fill the weld preparation with a minimum of one filling run and one capping run per side.

Ensure the mechanical attached GET is removed prior any preheat and welding.

### **WELD FINISHING**

It is recommended that all finished welds are inspected for cracks using either MPI or Dye Penetrant Inspection. It is preferable to use the MPI process. Any cracks detected must be completely gouged out and filled with weld. Finish the repair with grinding as detailed above and re-inspect for cracks.

### **CHANGE REGISTER**

Rev	Date	Changes from previous version
0	20/05/2022	Original Issue